

**TOSHIBA**  
 Leading Innovation >>>

Variable Speed Drive  
 TOSVERT VF-MB1

TOSVERT™  
**VF-MB1**



**VF-MB1**  
 1PH-200/240V-2.2kW/3HP

**警告**  
 けが、感電、火災のおそれがあります。  
 ・取り出し・取付けの際は必ず電源を断りこよ。  
 ・過電圧及び電圧変動後15分以内は  
 様子見を十分に行いこよ。  
 ・修理の際は必ず電源を断りこよ。  
**DANGER**  
 Risk of injury, electric shock or fire.  
 • Read the instruction manual.  
 • Do not open the cover while power is applied  
 or for 15 minutes after power has been  
 interrupted.  
 • Ensure proper earth connection.

Variable Speed Drive  
 Single phase-240V: 0.2kW to 2.2kW  
 Three phase-500V: 0.4kW to 15kW

# Shape Your Industry

- Fit your application by 3 advanced features.
- The VF-MB1 can drive elevator, lifting, conveyor, food & beverage processing, material handling, machine tool and various applications.

## SLIM SHAPE BODY

Side-by-side installation  
Flat Mounting Installation

## ADVANCED MOTOR DRIVE

Sensor-less Permanent Magnetic motor,  
SPM/IPM, and Induction Motor drive  
capability  
Toshiba unique magnetic pole position  
detection



## FLEXIBLE OPERATION

Simple Panel  
“Turn and Push” setting dial  
RUN and STOP keys  
Communication  
<Built-in>  
RS485 and CANopen®  
<Add-on option>  
EtherNet/IP™-Modbus® TCP,  
PROFIBUS® DP, DeviceNet™,  
EtherCAT® (coming soon)  
Dual rating  
Two types of rating can drive  
variable torque and constant  
torque applications with minimal  
drive size.

- DeviceNet™ is a trademark of ODVA (Open DeviceNet Vendor Association, Inc).  
- EtherCAT® is a registered trademark and patented technology, licensed by  
Beckhoff Automation GmbH.  
- CANopen® is a registered trademark of the CAN in Automation.  
- PROFIBUS® is a registered trademark of PROFIBUS NutzerOrganisation EV.  
- EtherNet/IP™ is a trademark of ControlNet International, Ltd.  
- Modbus® is a registered trademark of Schneider Automation.

\*Product names mentioned herein may be trademarks of their respective  
companies.



# SLIM SHAPE BODY

The slim design VF-MB1 fit to limited space and it can minimize the total machine spaces.



## Side-by-side installation

The VF-MB1 has been minimized width size in comparison with conventional model. In addition, side-by-side installation can save space in control cabinet (\*1).



DC bus terminals are located in top side for the model of 4.0kW or less, and bottom side for the model of 5.5kW to 15kW. These DC bus terminals are useful for Textile machinery in case of connecting multi-drive to the common DC bus supply.



45mm

- <45mm width>
  - 1ph-240V: 0.2kW to 0.75kW
  - 3ph-500V: 0.4kW to 1.5kW
- <60mm width>
  - 1ph-240V: 1.5kW and 2.2kW
  - 3ph-500V: 2.2kW and 4.0kW

## Slim design

For 240V-0.2kW to 0.75kW and 500V-0.4kW to 1.5kW models are fitted to 45mm slim design. And also, 240V-1.5kW to 2.2kW and 500V-2.2kW to 4.0kW models can be fitted to 60mm.

## Flat Mounting installation

The VF-MB1 can be mounted by Flat Mounting and front block can be attached 90 degree by using additional mount bracket (\*2). The space can be minimized with various installation (\*1).



For limited space For thin wall cubicle



# FLEXIBLE OPERATION

Flexible interface and improvement of a network communication can easily modify to arrange the wide range of application.

## Simple panel

Setting dial, 4 keys, and 4 small LEDs with Green 7 segments LEDs can be easy to set parameters and operations.



## Communication

### Built-in (RJ45)

- RS485 (Modbus® RTU) Baud rate 38.4 kbps max.
- CANopen®: Baud rate 1.0Mbps max.

### Optional (Add-on option)

- EtherNet/IP™-Modbus® TCP
- PROFIBUS® DP
- DeviceNet™
- EtherCAT® (Coming soon)
- CANopen®: Baud rate 1.0Mbps max.

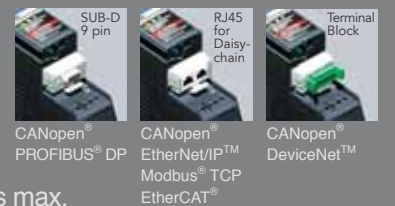

## Dual rating (CT/VT)

The VF-MB1 can be used for the constant torque and variable torque applications by dual rating operation. (5.5kW or larger type)  
For example, if variable torque application (fan and pump) require 15kW drives, it can be operated by 11kW rated of VF-MB1.

### Constant torque application

The torque value of constant torque application require the high torque level of different motor speed for Conveyors, Machine tool, Food machine and Elevator.



### Variable torque application

The torque value of variable torque application such as Fan, Pump and HVAC require low torque until starts to operating speed. (Compressor is excluded)

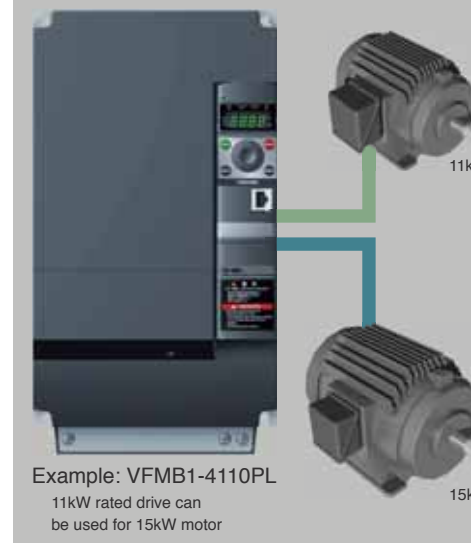
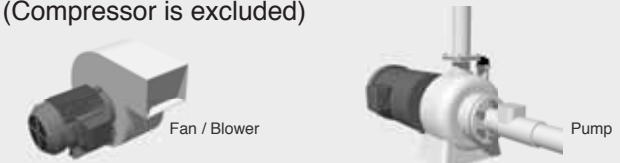

Example: VFMB1-4110PL  
11kW rated drive can be used for 15kW motor

\*1: Current reduction is required if VF-MB1 is installed into less ventilation spaces such as narrow space and side-by-side installation.  
\*2: The model whose front block is attached 90 degree is modified with additional mount bracket in factory. Please request 90 degree type with order, if it is required.



# ADVANCED MOTOR DRIVE

## Induction motor and Permanent Magnetic (PM) motor drive

The VF-MB1 controls not only 3-phase induction motors (Standard, High efficiency motor) but also Interior Permanent Magnetic Motor (IPM) and Surface Permanent Magnetic Motor (SPM) for high efficiency, high torque, energy saving, downsizing and lightening.

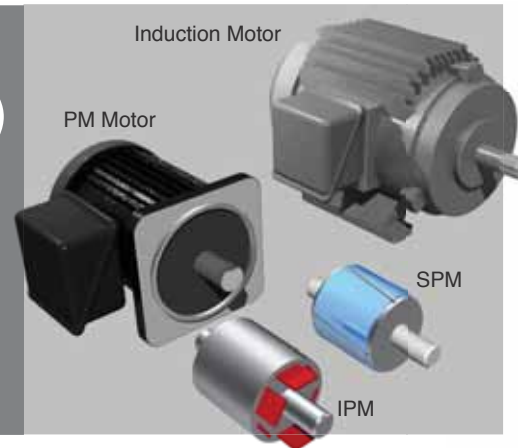

## PM drive technology

### Power-ON sensor less initial magnetic pole detection

- Initial magnetic pole position can be detected quickly without magnetic pole sensor.
  - Motor has high starting torque
  - It can minimize motor space, wiring and suitable with system requirements.
- (If the auto-tuning performed with motor rated parameter settings, high torque control operation can be achieved.)(\*1)

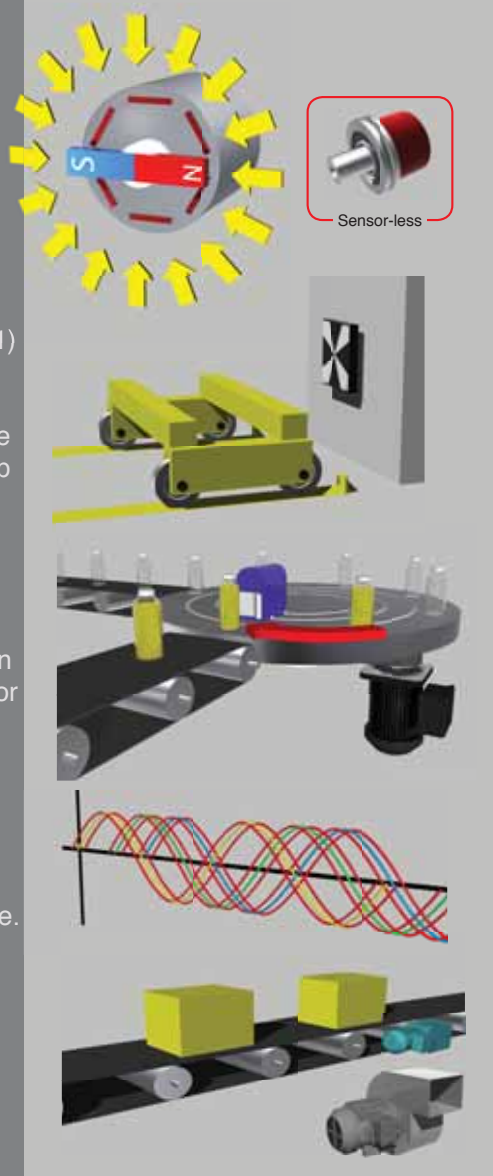

### Hit and stop function (Torque limit function)

Extra limit switch can be eliminated for conveyor, machine tool or other mechanical application by using Hit and stop function with torque limit function which can be adjusted torque value of motor torque, and motor rotation can be stopped by torque detection.

### Servo lock function

The VF-MB1 and PM motor combined, servo lock function can be used for automated system. It can control easily for stop and go applications by smooth speed reduction control for shock-less mechanical braking.

### Sensor less step-out detection

The VF-MB1 will keep detecting the pole position during PM motor is rotating. This function can prevent the step-out even if motor has impact and variable load torque.

### Constant and Variable torque control

The VF-MB1 can drive PM motor with not only variable torque but also constant torque which is required large torque when motor start to rotate.

# FLEXIBLE TERMINALS

## Control terminal layout

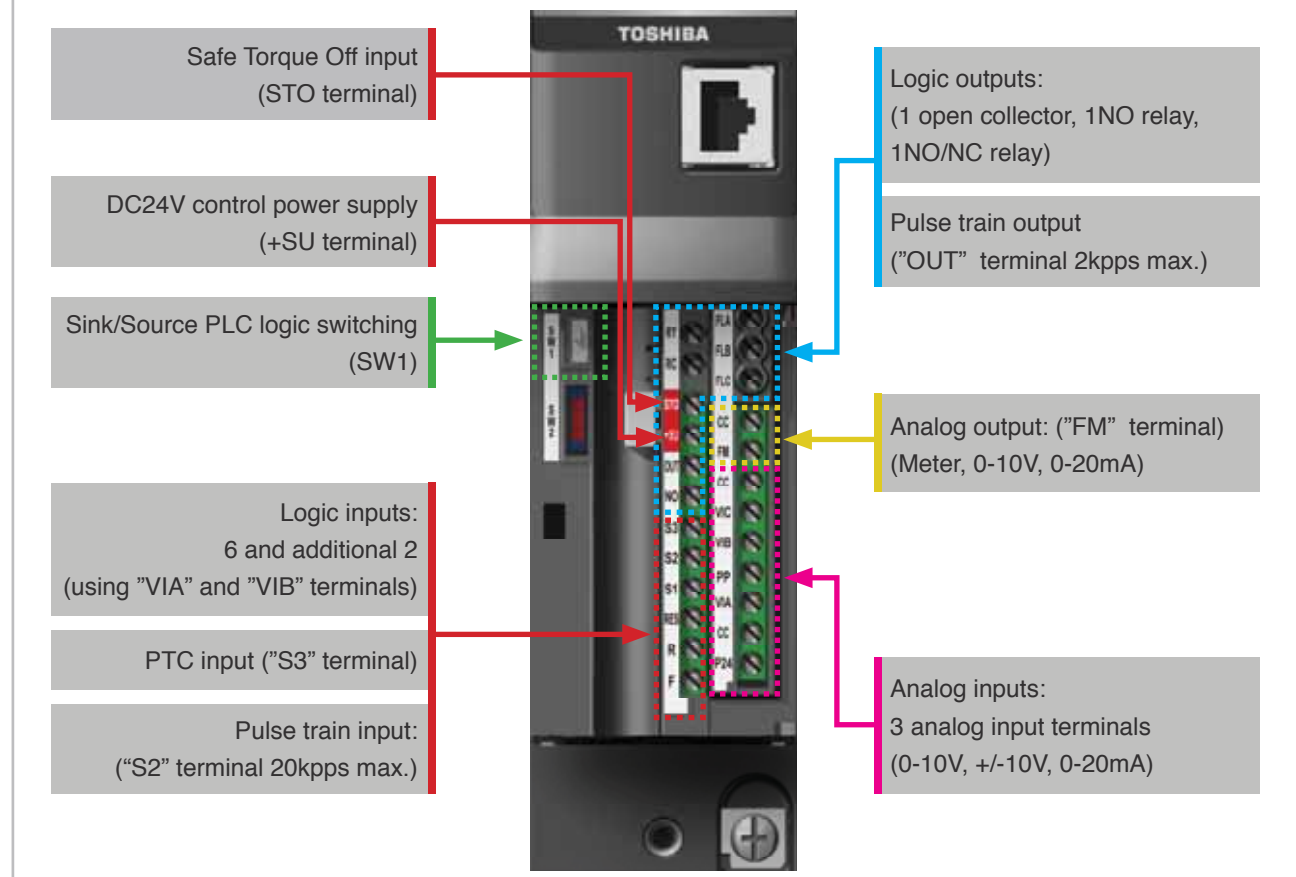

## Combination I/O

Multiple input terminal functions can be assigned with single input terminal, also output terminal can be assigned by "AND" and "OR" logics. This variety of functions allows for flexible system design.



## Covered input terminals

Easy connection of front side input terminals with safety quick open cover.



## Removable output terminal block

Easy install and maintenance by quick detachable output terminal block. (up to 4.0kW)

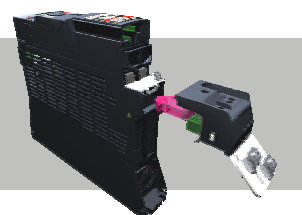

\*1: There is a possibility that some PM motors can NOT be driven by the VF-MB1 even if the motor parameters are set by auto-tuning function.

# FUNCTIONALITY

## Internal software

### PID Control

Temperature, Pressure, Flow and Motion control can be controlled with minimal over or less drive by using feedback analog signals from a sensor, detector and process control.

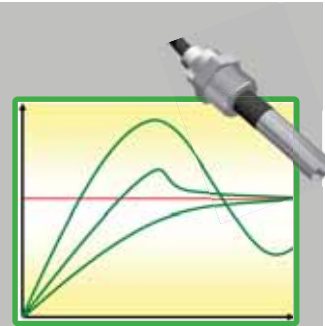

### Torque limit function

Output frequency can be decreased or increased according to the loading condition when the motor torque reaches the limit level such as paper and film rolling machine.

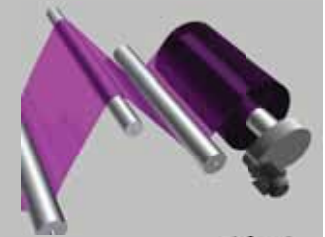

### Light-load high-speed operation

The light-load high-speed operation is used to improve the operating efficiency of the machine by increasing the rotational speed of the motor when it is operated under light load. This function is useful for constant-torque load applications which repeatedly drive light and heavy loads, such as lifts and transfer equipment.

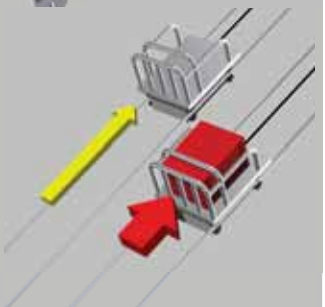

### Braking function

Lifts, crane and similar equipment require the smooth operation for braking and release timing with motor torque. The motor can produce enough torque before the brake is released by this function.



### Droop control

When single load is operated by multiple drives and motors, each drive and motor are necessary to control same value of load to prevent overload. This function can share the single loads to multiple drives.

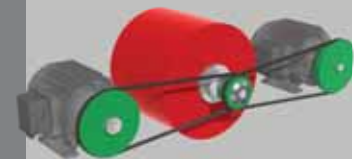

## Other functions

- V/F 5 points setting
- Forced fire-speed control
- Bumpless operation
- Tracing functions
- Integrating wattmeter
- Traverse
- Logic sequence function

# PROGRAMMING

The VF-MB1 can be programmed by using computer based software "Logic sequence setting tool" and "PCM001Z". Setup time and adjustment time for installation saving and appropriate setting for any conditions are achieved.

## Sequence programming software (Logic sequence setting tool)

The VF-MB1 has logic sequence function and once VF-MB1 is connected with computer, it can be programmed by "Logic sequence setting tool". "Logic sequence setting tool" can monitor the online input / output signals and monitoring status.



## Communication software (PCM001Z)

The PCM001Z communication software allows you to edit, monitor and trace parameter data on a computer, also operating condition can be analyzed by monitoring function. Inverter can be managed by easy data settings.

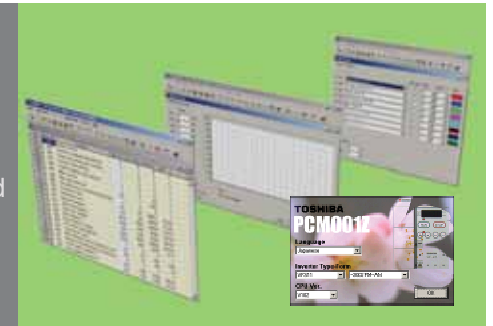

# EASY for ADVANCED CONTROL

## Simple setup by Easy key

For quick setting, pressing the EASY key on the panel allows you to operate the inverter by eight basic parameters. When setting each of the functions, press the EASY key to move to the standard mode by one-touch operation. In this mode, you can access all parameters. The maximum of 32 target parameters are displayed and assigned to suit with your specific setup requirements. You can also use the EASY key as a local/remote key to switch between panel and remote operation, and as a shortcut key to directly access any specific setup or display screen.

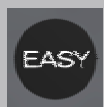

## Setting dial "turn-and-push"

The large setting dial at the center of the front panel allows you to set the parameters easily. Just turn the setting dial until you get the right parameter and push the setting dial to select. You can also use the setting dial to set the reference frequency.



# SAFETY

## Safety function (approval pending)

The VF-MB1 supports the Safe Torque Off (STO) function according to following standards.

- EN/IEC 61508
- EN954-1
- ISO 13849-1

The STO function can be set by using parameter settings. When STO input is open, drive stops and start is prohibited until STO input is reconnected.

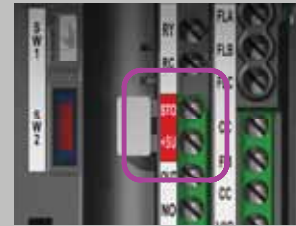

# ENVIRONMENT

## EMC noise filter inside

Built-in noise filters are ideal for site such as commercial facilities and offices where attention must be paid to peripheral devices. Compared to filter not integrated models, space and wiring can be saved by incorporating filter in the panel. The VF-MB1 complies with the European EMC Directive.

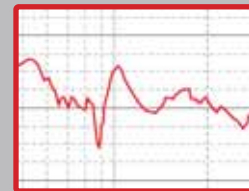

## Long lifetime

### 10 years of operation design

The main-circuit capacitor, cooling fan and control board capacitors are designed for 10 years lifetime design.

- Conditions -

- Ambient temperature: 40 °C
- Output current: 80% of the rated current
- Running time: 24 hours/365 days

- (\*1) The designed lifetime is calculated value.
- (\*2) It is not guaranteed time.

### Monitor informs when to replace major parts

The VF-MB1 tells you when to replace major parts and keeps track of the cumulative operation time. Since the VF-MB1 can generate warning, you can prevent a problem before it occurs.



## Eco design

The VF-MB1 complies with the European RoHS Directive.



# OPTIONAL DEVICES

## LCD Extension Panel Option (coming soon)



This panel is an 23-character x 8-line display, and can be used for simple setup and monitoring by selection of parameters using the jog dial. The display language can be switched between English and Japanese.

## LED Extension Panel Option (RKP002Z)



This RKP002Z is using 20 mm LEDs, the largest in its class in the market, to ensure outstanding visibility. It has also been designed to be fitted into panels for use as an extension panel or display.

(Note: Parameter copy function is available with RKP002Z-2 or later LED panels.)

## LED Extension Panel Option (RKP007Z)



Compact extension panel RKP007Z also available parameter read and writing.

## USB communications conversion unit (USB001Z)



This USB001Z converts USB port signal to the VF-MB1 built in (RJ45) port for data communication.

By using serial data communication, all parameters and monitoring data can be accessed for commissioning and maintenance.

## Add-on communication option

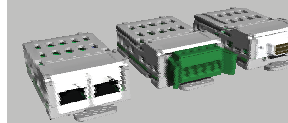

Add-on option lineups EtherNet/IP™ – Modbus® TCP, PROFIBUS® DP DeviceNet™, EtherCAT® and CANopen® (Insulated). The VF-MB1 can be connected to the common industrial networks.

## Touch Panel (TR PMIU)



3.5" and 5.7" touch panel can be connected with the VF-MB1 by using RS485 (Modbus® RTU) communication. All commands, monitoring and parameter setting is preprogrammed in touch panel programming software. System operation can be achieved simply and quickly.

## Intelligent I/O (TR SPUX)

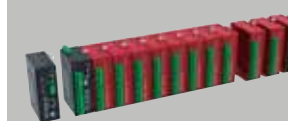

Advanced sequence programming for system control can be structured. Various analog and digital I/Os are arranged for wide range applications.



# Specifications

## Standard specifications

### 1-phase 240V

Item	Specification					
Input voltage class	1-phase 240V class					
Applicable motor (kW)	0.2	0.4	0.75	1.5	2.2	
Rating	Type	VFMB1S				
	Form	2002PL	2004PL	2007PL	2015PL	2022PL
	Capacity (kVA) Note 1)	0.6	1.3	1.8	3.0	4.2
	Output current (A) Note 2)	1.5 (1.5)	3.3 (3.3)	4.8 (4.8)	8.0 (8.0)	11.0 (11.0)
	Output voltage Note 3)	3-phase 200V to 240V				
	Overload current rating Note 2)	150%-60 seconds, 200%-0.5 second (120%-60 seconds, 165%-0.5 second)				
Power supply	Voltage-frequency	1-phase 200V to 240V - 50/60Hz				
	Allowable fluctuation	Voltage 170 to 264V Note 4), frequency ±5%				
	Required Power supply capacity (kVA) Note 5)	0.8	1.4	2.3	4.0	5.4
Protective method (IEC60529)	IP20					
Cooling method	Forced air-cooled					
Color	RAL7016					
Built-in filter	EMC filter					

### 3-phase 500V

Item	Specification									
Input voltage class	3-phase 500V class									
Applicable motor (kW)	0.4	0.75	1.5	2.2	4.0	5.5	7.5	11	15	
Rating	Type	VFMB1								
	Form	4004PL	4007PL	4015PL	4022PL	4037PL	4055PL	4075PL	4110PL	4150PL
	Capacity (kVA) Note 1)	1.1	1.8	3.1	4.2	7.2	11	13	21	25
	Output current (A) Note 2)	1.5 (1.5)	2.3 (2.3)	4.1 (4.1)	5.5 (5.5)	9.5 (9.5)	14.3 (17.0)	17.0 (23.0)	27.7 (33.0)	33.0 (40.0)
	Output voltage Note 3)	3-phase 380V to 500V								
	Overload current rating Note 2)	150%-60 seconds, 200%-0.5 second (120%-60 seconds, 165%-0.5 second)								
Power supply	Voltage-frequency	3-phase 380V to 500V - 50/60Hz								
	Allowable fluctuation	Voltage 323 to 550V Note 4), frequency ±5%								
	Required Power supply capacity (kVA) Note 5)	1.6	2.6	4.7	6.3	10.1	15.2	19.6	26.9	34.9
Protective method (IEC60529)	IP20									
Cooling method	Forced air-cooled									
Color	RAL7016									
Built-in filter	EMC filter									

Note 1. Capacity is calculated at 220V for the 240V models, at 440V for the 500V models.

Note 2. It is a value when the inverter overload characteristic selection (parameter  $RUL$ ) is the constant torque characteristic. Value in ( ) for the variable torque characteristic.

Note 3. Maximum output voltage is the same as the input voltage.

Note 4. At 180V-264V for the 240V models, at 342V-550V for the 500V models when the inverter is used continuously (load of 100%).

Note 5. Required power supply capacity varies with the value of the power supply side inverter impedance (including those of the input reactor and cables).

### Explanation of the type-form

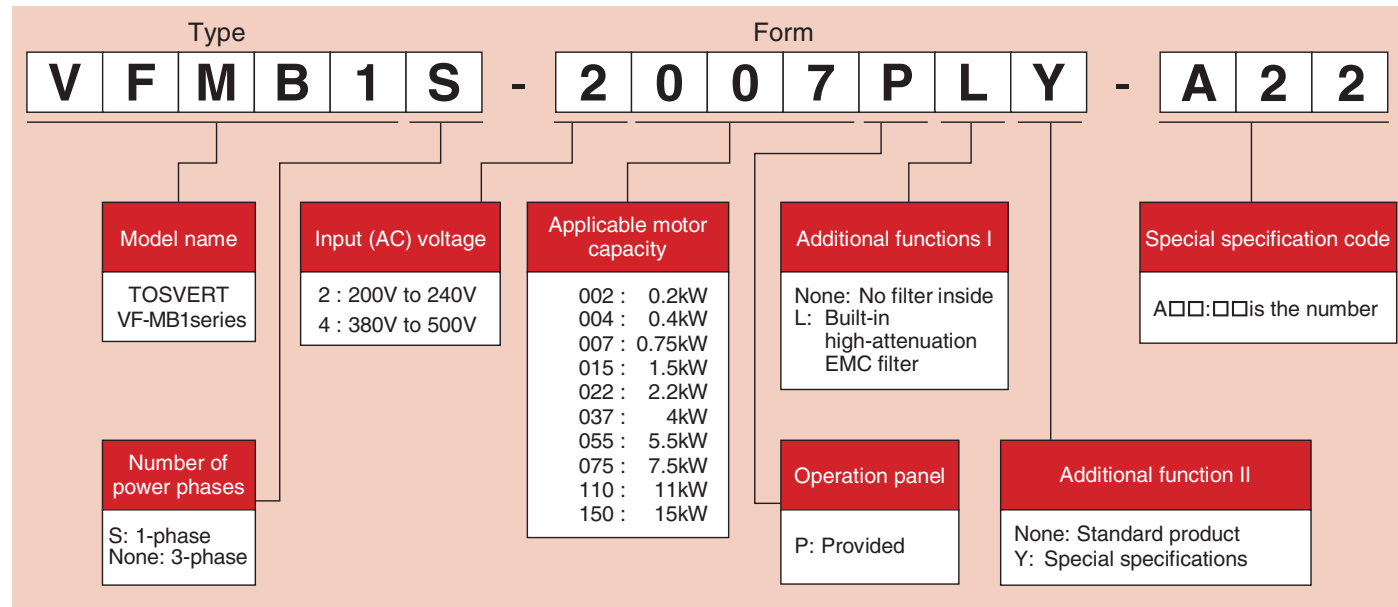

## Common specification

Item	Specification
Control system	Sinusoidal PWM control
Output voltage range Note1)	Adjustable within the range of 50 to 330V (240V class) and 50 to 660V (500V class) by correcting the supply voltage
Output frequency range	0.1 to 500.0Hz, default setting: 0.5 to 80Hz, maximum frequency: 30 to 500Hz
Minimum setting steps of frequency	0.1Hz: analog input (when the max. frequency is 100Hz), 0.01Hz: Operation panel setting and communication setting.
Frequency accuracy	Digital setting: within ±0.01% of the max. frequency (-10 to +60°C) Analog setting: within ±0.5% of the max. frequency (25°C ±10°C)
Voltage/frequency characteristics	V/f constant, variable torque, automatic torque boost, vector control, automatic energy-saving, dynamic automatic energy-saving control, PM motor control, V/F 5-point setting, Auto-tuning. Base frequency (20-500Hz) adjusting to 1 & 2, torque boost (0-30%) adjusting to 1 & 2, adjusting frequency at start (0.1-10Hz)
Frequency setting signal	Setting dial on the front panel, external frequency potentiometer (connectable to a potentiometer with a rated impedance of 1k-10kΩ), 0-10Vdc / -10+10Vdc (input impedance: 30kΩ), 4-20mA (input impedance: 250Ω).
Terminal board base frequency	The characteristic can be set arbitrarily by two-point setting. Possible to set: analog input (VIA, VIB, VIC).
Frequency jump	Three frequencies can be set. Setting of the jump frequency and the range.
Upper- and lower-limit frequencies	Upper-limit frequency: 0 to max. frequency, lower-limit frequency: 0 to upper-limit frequency
PWM carrier frequency	Adjustable range of 2.0k to 16.0kHz (default: 4.0kHz).
PID control	Setting of proportional gain, integral gain, differential gain and control wait time. Checking whether the amount of processing amount and the amount of feedback agree.
Acceleration/deceleration time	Selectable from among acceleration/deceleration times 1 & 2 & 3 (0.0 to 3600 sec.). Automatic acceleration/deceleration function. S-pattern acceleration/deceleration 1 & 2 and S-pattern adjustable. Control of forced rapid deceleration and dynamic rapid deceleration.
DC braking	Braking start-up frequency: 0 to maximum frequency, braking rate: 0 to 100%, braking time: 0 to 25.5 seconds, emergency DC braking, motor shaft fixing control.
Dynamic Braking Drive Circuit	Control and drive circuit is built in the inverter with the braking resistor outside (optional).
Input terminal function (programmable)	Possible to select from among about 110 functions, such as forward/reverse run signal input, jog run signal input, operation base signal input and reset signal input, to assign to 8 input terminals. Logic selectable between sink and source.
Output terminal functions (programmable)	Possible to select from among about 150 functions, such as upper/lower limit frequency signal output, low speed detection signal output, specified speed reach signal output and failure signal output, to assign to FL relay output, open collector output terminal, and RY output terminals.
Forward/reverse run	The RUN and STOP keys on the operation panel are used to start and stop operation, respectively. Forward/reverse run possible through communication and logic inputs from the terminal block.
Jog run	Jog mode, if selected, allows jog operation from the terminal board and also from remote keypad.
Preset speed operation	Base frequency + 15-speed operation possible by changing the combination of 4 contacts on the terminal board.
Retry operation	Capable of restarting automatically after a check of the main circuit elements in case the protective function is activated. 10 times (Max.) (selectable with a parameter)
Various prohibition settings / Password setting	Possible to write-protect parameters and to prohibit the change of panel frequency settings and the use of operation panel for operation, emergency stop or resetting. Possible to write-protect parameters by setting 4 digits password and terminal input.
Regenerative power ride-through control	Possible to keep the motor running using its regenerative energy in case of a momentary power failure (default: OFF).
Auto-restart operation	In the event of a momentary power failure, the inverter reads the rotational speed of the coasting motor and outputs a frequency appropriate to the rotational speed in order to restart the motor smoothly. This function can also be used when switching to commercial power.
Light-load high-speed operation	Increases the operating efficiency of the machine by increasing the rotational speed of the motor when it is operated under light load.
Drooping function	When two or more inverters are used to operate a single load, this function prevents load from concentrating on one inverter due to unbalance.
Override function	External input signal adjustment is possible to the operation frequency command value.
Relay output signal	1c-contact output and 1a-contact output: Note2) Maximum switching capacity : 250Vac-2A (At resistive load cosφ=1), 30Vdc-1A, 250Vac-1A (cosφ=0.4) Minimum permissible load : 5Vdc-100mA, 24Vdc-5mA
Protective function	Stall prevention, current limitation, over-current, output short circuit, over-voltage, over-voltage limitation, undervoltage, ground fault, detection, input phase failure, output phase failure, overload protection by electronic thermal function, armature over-current at start-up, load side over-current at start-up, over-torque, undercurrent, overheating, cumulative operation time, life alarm, emergency stop, various pre-alarms
Electronic thermal characteristic	Switching between standard motor and constant-torque VF motor, switching between motors 1 & 2, setting of overload trip time, adjustment of stall prevention levels 1 & 2, selection of overload stall
Reset function	Function of resetting by closing contact 1a or by turning off power or the operation panel. This function is also used to save and clear trip records.
Alarms	Over-current, overvoltage, overload, overheat, communication error, under-voltage, setting error, retry in process, upper/lower limits
Causes of failures	Over-current, overvoltage, overheat, output short-circuit, ground fault, overload on inverter, arm overcurrent at start-up, overcurrent on the load side at start-up, CPU fault, EEPROM fault, RAM fault, ROM fault, communication error. (Selectable: dynamic braking resistor overload, emergency stop, under-voltage, small current, over-torque, motor overload, input phase failure, output phase failure)
Monitoring function	Operation frequency, operation frequency command, forward/reverse run, output current, input voltage (DC detection), output voltage, torque, load factor of inverter, input power, output power, information on input terminals, information on output terminals, version of CPU1, version of CPU2, PID feedback value, frequency command (after compensation), causes of past trips 1 to 8, parts replacement alarm, cumulative operation time, overload and region setting
Past trip monitoring function	Stores data on the past eight trips: number of trips that occurred in succession, operation frequency, operation frequency command, forward/reverse run, output current, input voltage (DC detection), output voltage, information on input terminals, information on output terminals, and cumulative operation time when each trip occurred.
Output for frequency meter	Analog output for meter: 1mA dc full-scale dc ammeter 0 - 20mA (4 to 20mA) output: DC ammeter (allowable load resistance: Less than 750Ω) 0 - 10V output: DC voltmeter (allowable load resistance: Over 1kΩ) Resolution: Maximum of 1/1000
4-digit 7-segments LED	Frequency: inverter output frequency. Alarm: stall alarm "L", overvoltage alarm "P", overload alarm "I", overheat alarm "H", communication alarm "E" Status: inverter status (frequency, cause of activation of protective function, input/output voltage, output current, etc.) and parameter settings. Free-unit display: arbitrary unit (e.g. rotating speed) corresponding to output frequency.
Indicator	Lamps indicating the inverter status by lighting, such as RUN lamp, MON lamp, PRG lamp, % lamp, Hz lamp, EASY lamp, CANopen lamp, NET lamp. The charge lamp indicates that the main circuit capacitors are electrically charged.
Location of use	Indoors; not exposed to direct sunlight, corrosive gas, explosive gas, flammable gas, oil mist, or dust; and vibration of less than 5.9m/s <sup>2</sup> (10 to 55Hz).
Elevation	3000 m or less (current reduction required over 1000 m) Note 3)
Ambient temperature	-10 to +60°C Note 4)
Storage temperature	-25 to +70°C
Relative humidity	5 to 95% (free from condensation and vapor).

Note 1. Maximum output voltage is the same as the input voltage.

Note 2. A chattering (momentary ON/OFF of contact) is generated by external factors of the vibration and the impact, etc. In particular, please set the filter of 10ms or more, or timer for measures when connecting it directly with input unit terminal of programmable controller. Please use the OUT terminal as much as possible when the programmable controller is connected.

Note 3. Current must be reduced by 1% for each 100 m over 1000 m. For example, 90% at 2000m and 80% at 3000m.

Note 4. Above 50°C: Use the inverter with the output current reduced.  
Side by side installation (with no space between inverters): Use the inverter with the output current reduced.

# Dimensions

## External dimensions

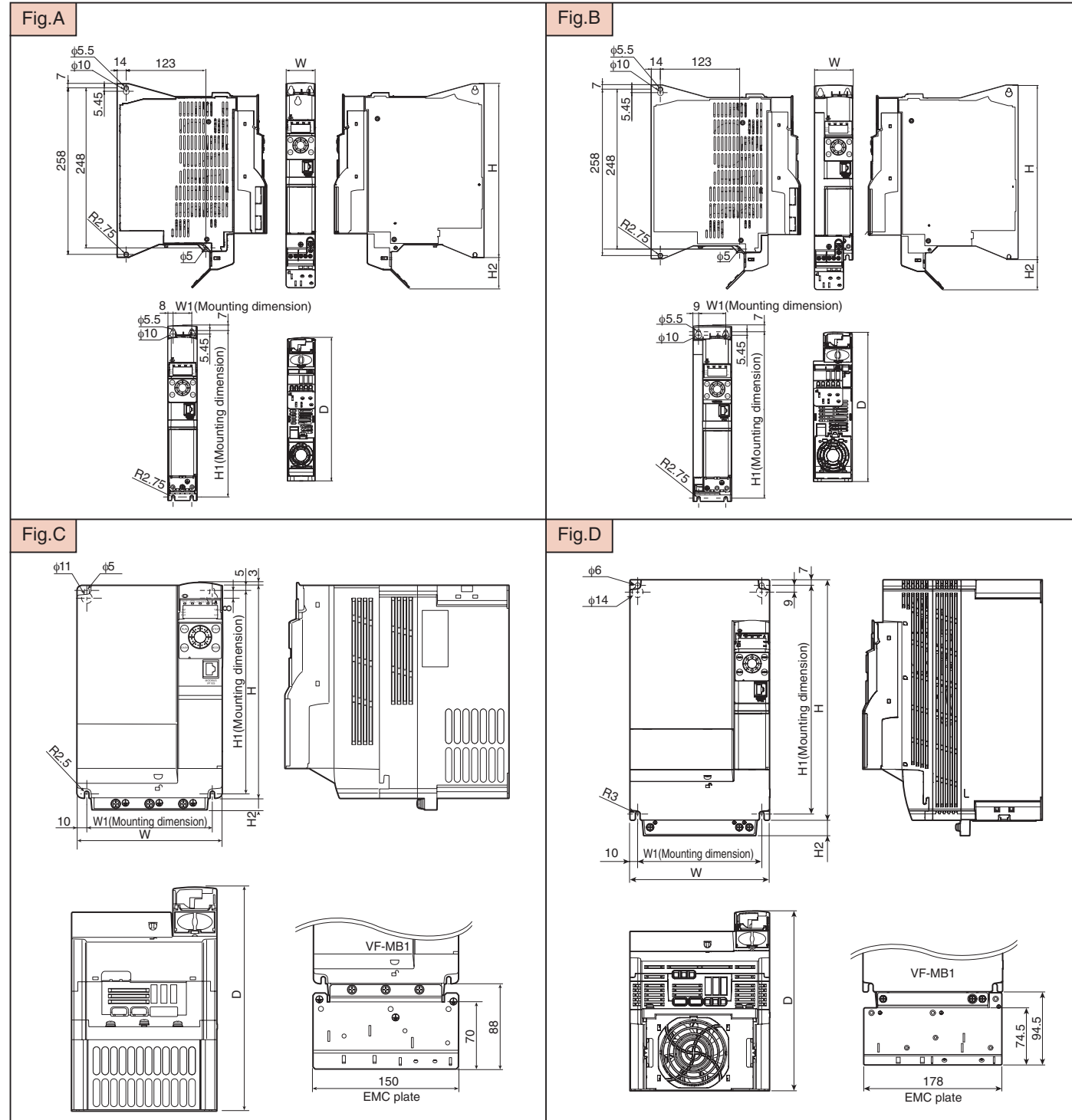

Voltage class	Applicable motor (kW)	Inverter type	Dimensions (mm)						Drawing	Approx. weight (kg)
			W	H	D	W1	H1	H2		
1-phase 240V	0.2	VFMB1S-2002PL	45	270	232	29	258	47	A	1.7
	0.4	VFMB1S-2004PL								
	0.75	VFMB1S-2007PL								
	1.5	VFMB1S-2015PL								
3-phase 500V	2.2	VFMB1S-2022PL	60	270	232	29	258	47	A	2.2
	0.4	VFMB1-4004PL								
	0.75	VFMB1-4007PL								
	1.5	VFMB1-4015PL								
	2.2	VFMB1-4022PL								
	4.0	VFMB1-4037PL								
	5.5	VFMB1-4055PL								
7.5	VFMB1-4075PL									
3-phase 500V	11	VFMB1-4110PL	150	310	232	130	210	12	C	4.3
	15	VFMB1-4150PL								
	15	VFMB1-4150PL								

Note. H dimension in Fig. C is not included in the protuberance for operation panel.

# Standard connection diagram

SINK (Negative)  
(common:CC)

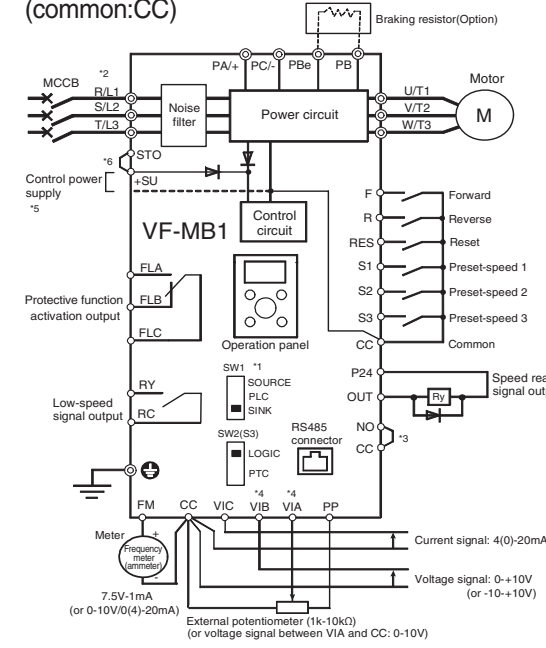

SOURCE (Positive)  
(common:P24)

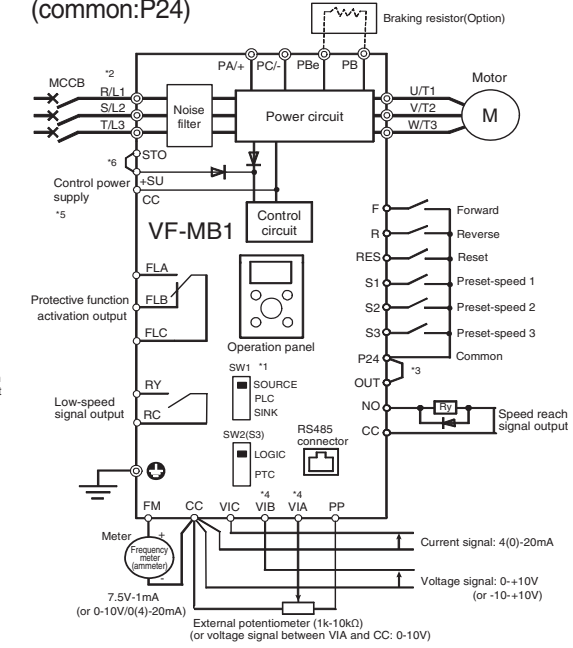

- \*1: Set the slide switch SW1 to sink side or source side.
- \*2: The T/L3 terminal is not provided for single-phase models. Use the R/L1 and S/L2/N terminal as input terminals.
- \*3: When using the OUT output terminal in sink logic mode, short the NO and CC terminals. When using the NO output terminal in source logic mode, short the P24 and OUT terminals.
- \*4: When VIA or VIB terminal is used as logic input terminal, set the parameter  $F_{109}$ .
- \*5: To supply control power from an external power supply for backing up the control power supplied from the inverter, an optional control power backup device (CPS002Z) is required. In such a case, the backup device is used at the same time with the internal power supply of the inverter. The optional control power backup unit can be used with both 240V and 500V models.
- \*6: When STO terminal is used as compliance with safety standards, refer to instruction manual.

## Power circuit terminal functions

Terminal symbol	Terminal function
	Grounding terminal for connecting inverter. There are 3 terminals in total.
R/L1, S/L2, T/L3	240V class: Single-phase 200 to 240V-50/60Hz * Single-phase inputs are R/L1 and S/L2/N terminals. 500V class: Three-phase 380 to 500V-50/60Hz
U/T1, V/T2, W/T3	Connect to a three-phase motor.
PBe, PB	Connect to braking resistors. Change parameters $F_{304}$ , $F_{305}$ , $F_{308}$ , $F_{309}$ if necessary.
PA+, PC-	These are a positive potential and negative potential terminals in the internal DC main circuit. DC common power can be input.

## Control circuit terminal functions

Terminal symbol	Input / output	Function	Electrical specifications
F	Input	Shorting across F-CC causes forward rotation; open causes slow-down and stop. (When Standby ST is always ON) 3 different functions can be assigned.	No voltage logic input 24Vdc-5mA or less
R	Input	Shorting across R-CC causes reverse rotation; open causes slow-down and stop. (When Standby ST is always ON) 3 different functions can be assigned.	
RES	Input	This inverter protective function is disabled if RES-CC is connected. Shorting RES-CC has no effect when the inverter is in a normal condition. 2 different functions can be assigned.	*Sink/Source and PLC selectable using slide switch SW1 (In case of sink logic is the left)
S1	Input	Shorting across S1-CC causes preset speed operation. 2 different functions can be assigned.	
S2	Input	Shorting across S2-CC causes preset speed operation. By changing parameter $F_{145}$ setting, this terminal can also be used as a pulse trains input terminal.	Pulse train input (S2) Pulse frequency range: 10pps-20kpps
S3	Input	Shorting across S3-CC causes preset speed operation. By changing slide switch SW2 and parameter $F_{147}$ setting, this terminal can also be used as a PTC input terminal.	PTC input (S3) PTC type: PT100
CC	Common to Input / output	Control circuit's equipotential terminal (3 terminals)	
PP	Output	Analog power supply output	10Vdc (permissible load current: 10mA)
VIA	Input	Multifunction programmable analog input. Factory default setting: 0-10Vdc (1/1000 resolution) and 0-60Hz (0-50Hz) frequency input. By changing parameter $F_{109}$ setting, this terminal can also be used as a multifunction programmable logic input terminal.	10Vdc (internal impedance: 30kΩ)
VIB	Input	Multifunction programmable analog input. Factory default setting: 0-10Vdc (1/1000 resolution) and 0-60Hz (0-50Hz) frequency input. The function can be changed to -10+10V input by parameter $F_{107}$ setting. By changing parameter $F_{109}$ setting, this terminal can also be used as a multifunction programmable logic input terminal.	10Vdc (internal impedance: 30kΩ)
VIC	Input	Multifunction programmable analog input. 0-20mA (4-20mA) input.	4-20mA (internal impedance: 250Ω)
FM	Output	Multifunction programmable analog output. Standard default setting: output frequency. The function can be changed to 0-10Vdc voltage or 0-20mA (4-20mA) current output by parameter $F_{58}$ setting.	1mA dc full-scale ammeter 0-10V DC volt meter 0-20mA (4-20mA) DC ammeter Permissible load resistance: 750Ω or less
P24	Output	24Vdc power output	24Vdc-100mA
+SU	Input	This terminal can be used as a common terminal when an external power supply is used by changing SW1 to PLC side.	
-5	Output	DC power input terminal for operating the control circuit. Connect a control power backup device (option) between +SU and CC. It is used with STO for safety function. +SU and STO terminals are short-circuited by metal bar at factory setting.	Voltage: 24Vdc±10% Current: 1A or more
STO	Input	When +SU and STO are short-circuited, the inverter is put into a standby state. (Factory setting) And when the circuit between them is opened, the motor is coasting stop. These terminals can be used for inter lock. This terminal is not a multifunction programmable input terminal. It is a terminal with the safety function that complies with SIL II of the safety standard IEC61508.	Independently of SW1 ON: DC17V or more OFF: Less than DC12V (OFF: Coast stop)
OUT NO	Output	Multifunction programmable open collector output. Standard default settings detect and output speed reach signal. 2 different functions can be assigned. The NO terminal is an isoelectric output terminal. It is isolated from the CC terminal. By changing parameter $F_{55}$ settings, these terminals can also be used as multifunction programmable pulse train output terminals.	Open collector output 24Vdc-100mA To output pulse trains, a current of 10mA or more needs to be passed. Pulse frequency range: 10pps-2kpps
FLA FLB FLC	Output	Multifunction programmable relay logic output. Detects the operation of the inverter's protection function. (Standard default setting) Contact across FLA-FLC is closed and FLB-FLC is opened during protection function operation.	Max. switching capacity 250Vac-2A ( $\cos\phi=1$ ): at resistive load 30Vdc-1A
RY RC	Output	Multifunction programmable relay contact output. Standard default settings detect and output low-speed signal output frequencies. 2 different functions can be assigned.	250Vac-1A ( $\cos\phi=0.4$ ) Min. permissible load 5Vdc-100mA 24Vdc-5mA



# Peripheral devices

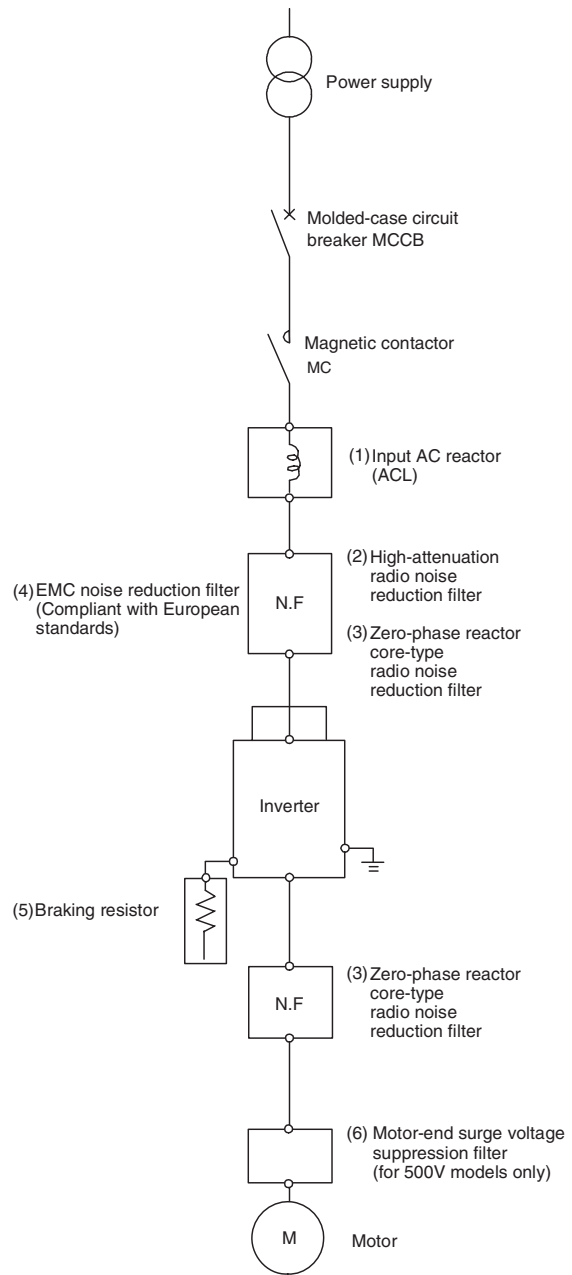

No.	Device	Function, Purpose, etc.
1	Input AC reactor	Used to improve the input power factor, reduce the harmonics, and suppress external surge on the inverter power source side. Install when the power capacity is 500kVA or more and 10 times or more than the inverter capacity or when a distorted wave generation source such as a thyristor unit or a large-capacity inverter is connected in the same distribution system.
2	High-attenuation radio noise reduction filter (LC filter) NF type	These types of filters are not necessary because all model have built-in EMC noise filter. • Effective to prevent interference with audio equipment used near the inverter. • Install on the input side of the inverter. • Provided with wide-range attenuation characteristics from AM radio bands to near 10MHz. • Use when equipment readily affected by noise is installed in the peripheral area.
3	Zero-phase reactor (inductive filter) Core type	• Effective to prevent interference with audio equipment used near the inverter. • Effective in noise reduction on both input and output sides of the inverter. • Provided with attenuation characteristics of several dB in frequencies from AM radio bands to 10MHz. • For noise countermeasures, insert on the secondary side of the inverter.
4	EMC noise reduction filter (Compliant with European standards)	A high-attenuation compact EMC noise filter used to suppress the conductive noise.
5	Braking resistor	Use when rapid deceleration or stop is frequently required or when it is desired to reduce the deceleration time with large load. This resistor consumes regenerative energy during power generation braking.
6	Motor-end surge voltage suppression filter (for 500V models only)	In case that 500V class motor is driven by inverter, use an insulation-reinforced motor or install the surge voltage restraint filter to prevent degrading motor insulation caused by surge voltage generation depending on cable length and wiring method.
7	LCD extension panel	It is 23-characters and 8-lines displays, and can be used for simple setup and monitoring by selection of parameters using the setting dial.
8	LED extension panel (with parameter writer function)	It is provided with an LED display, RUN/STOP key, UP/DOWN key, monitor key, and enter key. Setup parameters for three inverters can be stored to this unit.
9	USB communication conversion unit	This unit is connected to a PLC or a computer to enable data communications. By connecting the connector cable, parameters can be easily adjusted, and data easily saved and written.
10	Frequency meter	Use to mount the meter on an external operation unit.
11	FRH kit	FRH-kit includes frequency setting resistor, panel and knob for an external operation unit.

## Wiring devices

Voltage class	Applicable motor (kW)	Inverter type	Input current (A)		Molded -case circuit breaker (MCCB)		Magnetic contactor (MC) Note1)2)		Wire size (mm <sup>2</sup> ) Note7)		
			Rated current (A)		Earth leakage circuit breaker (ELCB) Note3)		Rated current (A)		Main circuit Note4)	Braking resistor (optional)	Grounding cable Note6)
			Without reactor	With ACL	Without reactor	With ACL	Without reactor	With ACL			
1-phase 240V	0.2	VFMB1S-2002PL	3.4	2.4	5	5	20	20	1.5	1.5	2.5
	0.4	VFMB1S-2004PL	6.0	4.4	10	10	20	20	1.5	1.5	2.5
	0.75	VFMB1S-2007PL	10.1	8.1	15	10	20	20	1.5	1.5	2.5
	1.5	VFMB1S-2015PL	17.6	15.3	30	20	32	20	2.5	1.5	2.5
	2.2	VFMB1S-2022PL	23.9	21.3	30	30	32	32	4.0	1.5	4.0
3-phase 500V	0.4	VFMB1-4004PL	2.1	1.5	5	5	20	20	1.5	1.5	2.5
	0.75	VFMB1-4007PL	3.6	2.6	5	5	20	20	1.5	1.5	2.5
	1.5	VFMB1-4015PL	6.5	4.7	10	10	20	20	1.5	1.5	2.5
	2.2	VFMB1-4022PL	8.7	6.4	15	10	20	20	1.5	1.5	2.5
	4.0	VFMB1-4037PL	13.7	10.3	20	15	20	20	2.5	1.5	2.5
	5.5	VFMB1-4055PL	20.7	14.0	30	20	32	20	4.0	1.5	4.0
	7.5	VFMB1-4075PL	26.5	18.1	40	30	32	32	6.0	2.5	6.0
11	VFMB1-4110PL	36.6	24.1	50	40	50	32	10.0	4.0	10.0	
15	VFMB1-4150PL	47.3	36.6	60	50	60	50	16.0	6.0	16.0	

Note 1: Be sure to attach a surge killer to the exciting coil of the relay and the magnetic contactor.  
 Note 2: When using the auxiliary contacts 2a of the magnetic contactor MC for the control circuit, connect the contacts 2a in parallel to increase reliability.  
 Note 3: Select an MCCB with a rated interrupting current appropriate to the capacity of the power supply, because short-circuit currents vary greatly depending on the capacity of the power supply and the condition of the wiring system. The MCCB, MC and ELCB in this table were selected, on the assumption that a power supply with a normal capacity would be used.  
 Note 4: Sizes of the wires connected to the input terminals R/L1, S/L2 and T/L3 and the output terminals U/T1, V/T2 and W/T3 when the length of each wire does not exceed 30m.  
 Note 5: For the control circuit, use shielded wires 0.75 mm<sup>2</sup> or more in diameter.  
 Note 6: For grounding, use a cable with a size equal to or larger than the above.  
 Note 7: The wire sizes specified in the above table apply to HIV wires (copper wires shielded with an insulator with a maximum allowable temperature of 75°C) used at an ambient temperature of 50 °C or less.

# Options

## Table of add-on communication options

Name	Type-form
PROFIBUS DP communication option	PDP003Z
DeviceNet communication option	DEV003Z
EtherNet/IP-Modbus TCP communication option	IPE002Z
EtherCAT communication option	IPE003Z
CANopen daisy chain option	CAN001Z
CANopen SUB-D connector option	CAN002Z
CANopen terminal option	CAN003Z

## LCD extension panel

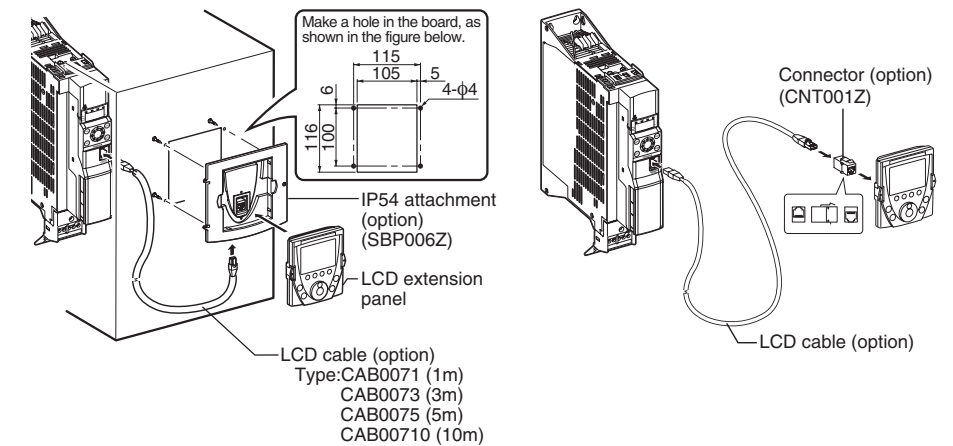
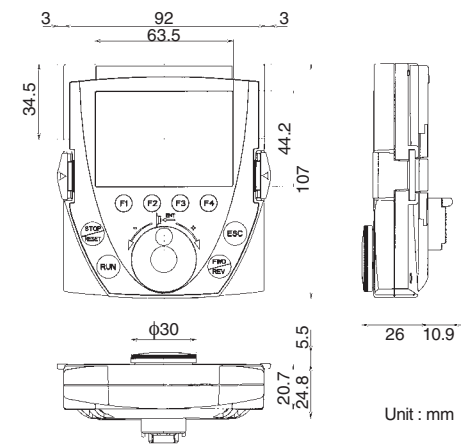

## LED extension panel

Type : RKP002Z

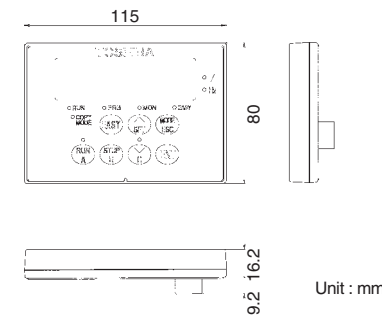

## Panel cutout dimension

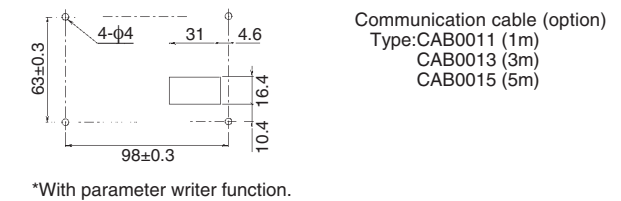

## USB communication conversion unit

Type : USB001Z

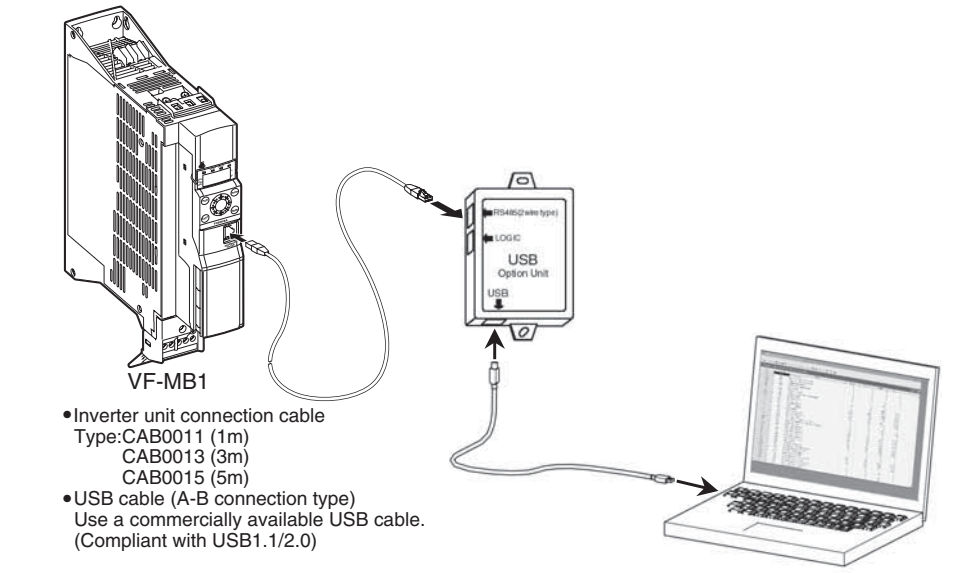
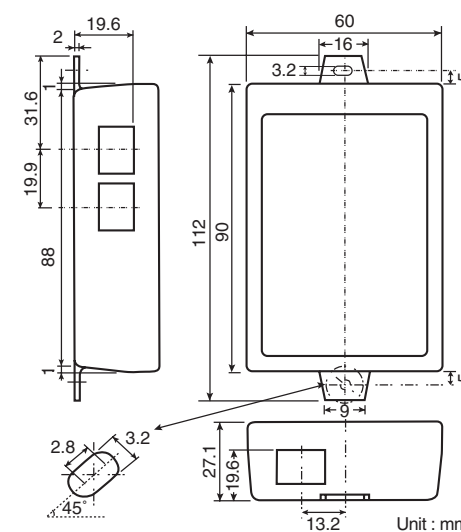

# For inverter users

## 1. When studying how to use our inverters

### Notes

#### Leakage current

This inverter uses high-speed switching semiconductors for PWM control. When a relatively long cable is used for power supply to an inverter, current may leak from the cable or the motor to the ground because of its capacitance, adversely affecting peripheral equipment. The intensity of such a leakage current depends on the PWM carrier frequency setting, the lengths of the input and output cables, etc., of the inverter. To prevent current leakage, it is recommended to take the following measures.

#### Effects of leakage current

Leakage current which increases when an inverter is used may pass through the following routes:

- Route (1) ... Leakage due to the capacitance between the ground and the noise reduction filter
  - Route (2) ... Leakage due to the capacitance between the ground and the inverter
  - Route (3) ... Leakage due to the capacitance between ground and the cable connecting the inverter and the motor
  - Route (4) ... Leakage due to the capacitance of the cable connecting the motor and an inverter in another power distribution line
  - Route (5) ... Leakage through the grounding line common to motors
  - Route (6) ... Leakage to another line because of the capacitance of the ground
- Leakage current which passes through the above routes may cause the following trouble.
- Malfunction of a leakage circuit breaker (ELCB) in the same or another power distribution line
  - Malfunction of a ground-relay installed in the same or another power distribution line
  - Noise produced at the output of an electronic device in another power distribution line
  - Activation of an external thermal relay installed between the inverter and the motor, at a current below the rated current

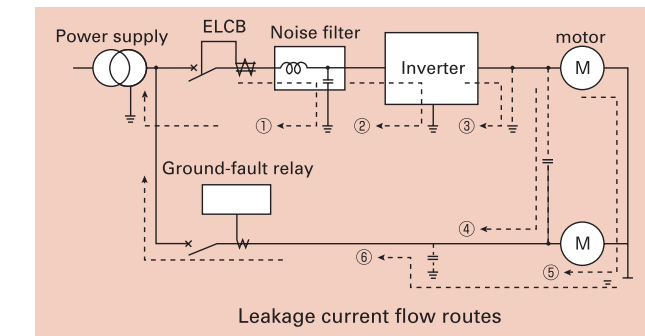

#### Measures against effects of leakage current

The measures against the effects of leakage current are as follows:

- 1) Measures to prevent the malfunction of leakage circuit breakers (ELCB)
    - (1) Decrease the PWM carrier frequency of the inverter. *Note*
    - (2) Use radio-frequency interference-proof ELCBs as ground-fault interrupters in not only the system into which the inverter is incorporated but also other systems. When ELCBs are used, the PWM carrier frequency needs to be increased to operate the inverter.
    - (3) When connecting multiple inverters to a single ELCB, use an ELCB with a high current sensitivity or reduce the number of inverters connected to the ELCB.
  - 2) Measures against malfunction of ground-fault relay:
    - (1) Decrease the PWM carrier frequency of the inverter. *Note*
    - (2) Install ground-fault relays with a high-frequency protective function in both the same and other lines. When ELCBs are used, the PWM carrier frequency needs to be increased to operate the inverter.
  - 3) Measures against noise produced by other electric and electronic systems:
    - (1) Separate the grounding line of the inverter from that of the affected electric and electronic systems.
    - (2) Decrease the PWM carrier frequency of the inverter. *Note*
  - 4) Measures against malfunction of external thermal relays:
    - (1) Remove the external thermal relay and use the electronic thermal function of the inverter instead of it. (Unapplicable to cases where a single inverter is used to drive more than one motor. Refer to the instruction manual for measures to be taken when thermal relays cannot be removed.)
    - (2) Decrease the PWM carrier frequency of the inverter. *Note*
  - 5) Measures by means of wiring and grounding
    - (1) Use a grounding wire as large as possible.
    - (2) Separate the inverter's grounding wire from that of other systems or install the grounding wire of each system separately to the grounding point.
    - (3) Ground (shield) the main circuit wires with metallic conduits.
    - (4) Use the shortest possible cables to connect the inverter to the motor.
    - (5) If the inverter has a high-attenuation EMC noise reduction filter, change the grounding capacitor switch to reduce the leakage current. Note that doing so leads to a reduction in the noise attenuating effect.
- Note*) In the case of this inverter, the PWM carrier frequency can be decreased to 2.0kHz. Decreasing the carrier frequency results in an increase in electromagnetic noise from the motor.

#### Ground fault

Before beginning operation, thoroughly check the wiring between the motor and the inverter for incorrect wiring or short circuits. Do not ground the neutral point of any star-connected motor.

#### Radio interference

##### [Noise produced by inverters]

Since this inverter performs PWM control, it produces noise and sometimes affects nearby instrumental devices, electrical and electronic systems, etc. The effects of noise greatly vary with the noise resistance of each individual device, its wiring condition, the distance between it and the inverter, etc.

##### [Measures against noises]

According to the route through which noise is transmitted, the noises produced by an inverter are classified into transmission noise, induction noise and radiation noise.

#### [Examples of protective measures]

- Separate the power line from other lines, such as weak-current lines and signal lines, and install them apart from each other.
  - Install a noise reduction filter in each inverter. It is effective for noise prevention to install noise reduction filter in other devices and systems, as well.
  - Shield cables and wires with grounded metallic conduits, and cover electronic systems with grounded metallic cases.
  - Separate the power distribution line of the inverter from that of other devices and systems.
  - Install the input and output cables of the inverter apart from each other.
  - Use shielded twisted pair wires for wiring of the weak-current and signal circuits, and always ground one of each pair of wires.
  - Ground the inverter with grounding wires as large and short as possible, separately from other devices and systems.
- All models, noise can be greatly reduced as they have a built-in EMC noise reduction filter on their input side.**

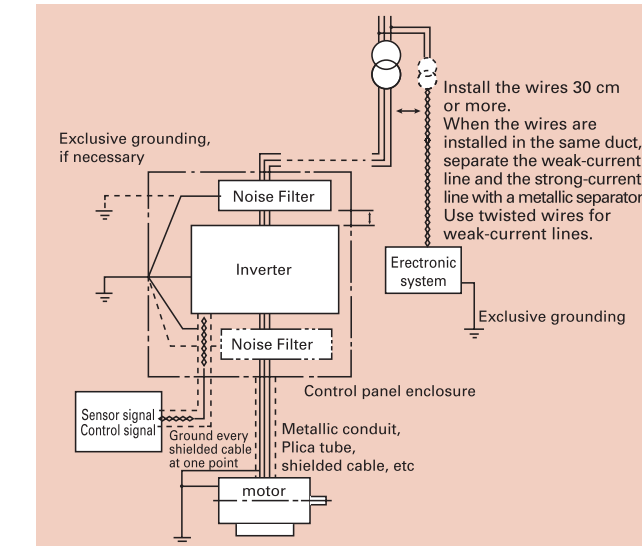

#### Power factor improvement capacitors

Do not install a power factor improvement capacitors on the output side of the inverter. Installing a power factor improvement capacitor on the output side causes current containing harmonic components to flow into the capacitor, adversely affecting the capacitor itself or causing the inverter to trip. To improve the power factor, install an input AC reactor or a DC reactor on the primary side of the inverter.

#### Installation of input AC reactors

These devices are used to improve the input power factor and suppress high harmonic currents and surges. Install an input AC reactor when using this inverter under the following conditions:

- (1) When the power source capacity is 500kVA or more, and when it is 10 times or more greater than the inverter capacity.
- (2) When the inverter is connected the same power distribution system as a thyristor-committed control equipment.
- (3) When the inverter is connected to the same power distribution system as that of distorted wave-producing systems, such as arc furnaces and large-capacity inverters.

## 2. Selecting the Capacity (model) of the Inverter

### Selection

#### Capacity

Refer to the applicable motor capacities listed in the standard specifications. When driving a high-pole motor, special motor, or multiple motors in parallel, select such an inverter that the sum of the motor rated current multiplied by 1.05 to 1.1 is less than the inverter's rated output current value.

#### Acceleration/deceleration times

The actual acceleration and deceleration times of a motor driven by an inverter are determined by the torque and moment of inertia of the load, and can be calculated by the following equations.

The acceleration and deceleration times of an inverter can be set individually. In any case, however, they should be set longer than their respective values determined by the following equations.

Acceleration time	$t_a = \frac{(JM+JL) \times \Delta N}{9.56 \times (TM-TL)}$ (sec.)
Deceleration time	$t_d = \frac{(JM+JL) \times \Delta N}{9.56 \times (TB-TL)}$ (sec.)
Conditions	JM :Moment of inertia of motor (kg·m <sup>2</sup> )
	JL :Moment of inertia of load (kg·m <sup>2</sup> ) (converted into value on motor shaft)
	$\Delta N$ :Difference in rotating speed between before and after acc. or dec. (min <sup>-1</sup> )
	TL :Load torque (N·m)
	TM :Motor rated torque x 1.2~1.3 (N·m) ...V/f control
	TM :Motor rated torque x 1.5 (N·m) ...Vector operation control
	TM :Motor rated torque x 1.1 (N·m) ...V/f control
	TM :Motor rated torque x 1.2 (N·m) ...Vector operation control
TB :Motor rated torque x 0.2 (N·m)	
(When a braking resistor or a braking resistor unit is used: Motor rated torque x 0.8~1.0 (N·m))	

#### Allowable torque characteristics

When a standard motor is combined with an inverter to perform variable speed operation, the motor temperature rises slightly higher than it normally does during commercial power supply operation. This is because the inverter output voltage has a sinusoidal (approximate)

PWM waveform. In addition, the cooling becomes less effective at low speed, so the torque must be reduced according to the frequency. Regarding the allowable torque characteristic, please confirm its motor manufacturer.

When constant-torque operation must be performed at low speeds, use a Toshiba VF motor designed specifically for use with inverters.

#### Starting characteristics

When a motor is driven by an inverter, its operation is restricted by the inverter's overload current rating, so the starting characteristic is different from those obtained from commercial power supply operation.

Although the starting torque is smaller with an inverter than with the commercial power supply, a high starting torque can be produced at low speeds by adjusting the V/f pattern torque boost amount or by employing vector control. When a larger starting torque is necessary, select an inverter with a larger capacity and examine the possibility of increasing the motor capacity.

## 3. When installing, wiring and operating the inverter

### Installing and wiring

#### Installing precautions

- (1) Do not install in any location of high temperature, high humidity, moisture condensation and freezing. Do not install the inverter where there are gases that corrode metal or solvents that adversely affect plastic. Avoid locations where there is exposure to water and/or where there may be large amounts of dust and metallic fragments. In this case, please install inverters in the enclosure type cabinet. The cabinet must be considered its size and the cooling method to allow the specifications of an ambient temperature for inverters.
- (2) Must be installed in non-inflammables such as metals. The rear panel gets very hot. If installation is in an inflammable object, this can result in fire.
- (3) Inverters should be arranged in horizontal rows.

#### Wiring precautions

##### Installing a molded-case circuit breaker [MCCB]

- (1) Install a molded-case circuit breaker (MCCB) on the inverter's power supply input to protect the wiring.
- (2) Avoid turning the molded-case circuit breaker on and off frequently to turn on/off the motor.
- (3) To turn on/off the motor frequently, close/break the control terminals F (or R)-CC.

##### Installing a magnetic contactor [MC] [primary side]

- (1) To prevent an automatic restart after the power interruption or overload relay has tripped, or actuation of the protective circuit, install an electro-magnetic contact in the power supply.
- (2) The inverter is provided with a failure detection relay (FL), so that, if its contacts are connected to the operation circuit of the magnetic contactor on the primary side, the magnetic contactor will be opened when the protective circuit of the inverter is activated.
- (3) The inverter can be used without a magnetic contactor. In this case, use an MCCB (equipped with a voltage tripping device) for opening the primary circuit when the inverter protective circuit is activated.
- (4) Avoid turning the magnetic contactor on and off frequently to turn on/off the motor.
- (5) To turn on/off the motor frequently, close/break the control terminals F (or R)-CC.
- (6) Install surge suppressor on any magnetic contactor and relay coils used around the inverter.
- (7) If using a braking resistor, install a magnetic contactor (MC) to the power supply of the inverter, so that the power circuit opens when the internal overload relay of the braking resistor is activated.

##### Installing a magnetic contactor [MC] [secondary side]

- (1) As a rule, if a magnetic contactor is installed between the inverter and the motor, do not turn on/off while running. (If the secondary-side contactor is turned on/off while running, a large current may flow in the inverter, causing inverter damage and failure.)
- (2) A magnetic contactor may be installed to change the motor or change to the commercial power source when the inverter is stopped. Always use an interlock with the magnetic contactor in this situation so that the commercial power supply is not applied to the inverter's output terminals.

#### External signal

- (1) Use a relay rated for low currents. Mount a surge suppressor on the excitation coil of the relay.
- (2) When wiring the control circuit, use shielded wires or twisted pair cables.
- (3) Because all of the control terminals except FLA, FLB, FLC, RY and RC are connected to electronic circuits, insulate these terminals to prevent them from coming into contact with the main circuit.

#### Installing an overload relay

This inverter has an electronic-thermal overload protective function. However, in the following cases, the thermal relay operation level must be adjusted or an overload relay matching the motor's characteristics must be installed between the inverter and the motor.

- (a) When using a motor having a rated current value different from that of the equivalent.
  - (b) When driving several motors simultaneously.
- (2) When using the inverter to control the operation of a constant-torque motor (VF motor), change the protective characteristic of the electronic thermal relay according to the setting of the VF motor.
  - (3) In order to adequately protect a motor used for low-speed operation, we recommend the use of a motor equipped with an embedded thermal relay.

#### Wiring

- (1) Do not connect input power to the output (motor side) terminals (U/T1, V/T2, W/T3). That will destroy the inverter and may result in fire. Please pay attentions of wiring before power supply turns-on.
- (2) The DC terminals (PA+, PC-, PB and PB) are for specified options. Do not connect other devices to these terminals.
- (3) Within 15 minutes after turning off input power, do not touch wires of devices (MCCB) connected to the input side of the inverter.

#### Grounding

The inverters and motors must be connected to ground securely. In case of grounding for inverters, please use the grounding terminal of the inverter.

### Operating precautions

- (1) The inverter operates in abnormal circumstances the security function, and stops outputting. However, the inverters can not stop the motors quickly. Please install the

mechanical brake or maintenance function in the mechanical equipment and the device for which the emergency stop is necessary.

- (2) When you drive the machine and the device that hangs the load repeatedly with the inverter, the semiconductor within inverter might cause thermal fatigue, and it come to have a short life if a big current flows repeatedly when driving and stopping. In this case, it is possible to extend life span by controlling the starting current and the load current low or setting the PWM carrier frequency low. If you can not decrease the starting current, please select larger capacity of inverters for current margins.

## 4. When changing the motor speed

### Application to standard motors

#### Vibration

When a motor is operated with an inverter, it experiences more vibrations than when it is operated by the commercial power supply. The vibration can be reduced to a negligible level by securing the motor and machine to the base firmly.

If the base is weak, however, the vibration may increase at a light load due to resonance with the mechanical system

#### Acoustic noise

The magnetic noise of motors with inverter drives is changed by PWM carrier frequency. In case of high PWM carrier frequency settings, its acoustic noise is almost same as commercial power supply drives. Moreover, when the motors are operated over rated rotation, the windy noise of the motors is increased.

#### Reduction gear, belt, chain

Note that the lubrication capability of a reducer or a converter used as the interface of the motor and the load machine may be affected at low speeds.

When operating at a frequencies exceeding 60 Hz or higher, power transmission mechanisms such as reduction gear, belts and chains, may cause problems such as production of noise, a reduction in strength, or shortening of service life.

#### Frequency

Before setting the maximum frequency to 60 Hz or higher, confirm that this operating range is acceptable for the motor.

#### Starting method

When you drive the motor with changeable connection between star-connection and delta-connection for decreasing starting current, please connect delta-connection only. If you change motor connection while inverter drives, the protective function of inverter occurs.

### Application to special motors

#### Gear motor

When using an inverter to drive a gear motor, inquire of the motor manufacturer about its continuous operation range due to the followings:

- The low-speed operation of a gear motor may cause insufficient lubrication
- The loss of a gear may be increasing than commercial power supply drives.
- In case of the high frequency operation, the acoustic noise and motor temperature may be higher.

#### Toshiba Gold Motor (High-efficiency power-saving motor)

Inverter-driven operation of Toshiba Gold Motors is the best solution for saving energy. This is because these motors have improved efficiency, power factor, and noise/vibration reduction characteristics when compared to standard motors.

#### Pole-changing motor

Pole-changing motors can be driven by this inverter. Before changing poles, however, be sure to let the motor come to a complete stop. If you change motor connection while inverter drives, the protective function of inverter occurs.

#### Underwater motors

Note that underwater motors have higher rated current than general motors. The current ratings of underwater motors are relatively high. So, when selecting an inverter, you must pay special attention to its current rating so that the current rating of the motor is below that of the inverter.

When the lengths of the motor cable are long, please use thicker cable than a table of 'Wiring devices' because the maximum torque is decreased by the voltage dropping.. Moreover, please pay attention to select leakage circuit breakers.

#### Single-phase motor

Because single-phase motors are equipped with a centrifugal switch and capacitors for starting, they cannot be driven by an inverter. When single phase motors are driven by inverters, a centrifugal switch and capacitors may be broken. If only a single-phase, power system is available a 3-phase motor can be driven by using a single-phase input inverter to convert it into a 3-phase 200V output. (A special inverter and a 3-phase 200V motor are required.)

#### Braking motor

When using a braking motor, if the braking circuit is directly connected to the inverter's output terminals, the brake cannot be released because of the lowered starting voltage. Therefore, when using a braking motor, connect the braking circuit to the inverter's power supply side, as shown on the below. Usually, braking motors produce larger noise in low speed ranges.

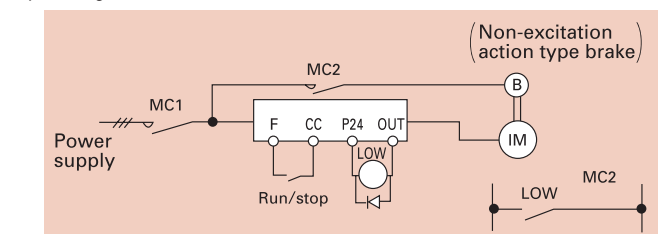

## To users of our inverters:

Our inverters are designed to control the speeds of three-phase induction motors for general industry.

### Precautions

- Read the instruction manual before installing or operating the inverter unit and store it in a safe place for reference.
- When using our inverters for equipment such as nuclear power control, aviation and space flight control, traffic, and safety, and there is a risk that any failure or malfunction of the inverter could directly endanger human life or cause injury, please contact our headquarter as below. Special precautions must be taken and such applications must be studied carefully.
- When using our inverters for critical equipment, even though the inverters are manufactured under strict quality control always fit your equipment with safety devices to prevent serious accident or loss should the inverter fail (such as issuing an inverter failure signal).
- Do not use our inverters for any load other than three-phase induction motors.
- None of Toshiba, its subsidiaries, affiliates or agents, shall be liable for any physical damages, including, without limitation, malfunction, anomaly, breakdown or any other problem that may occur to any apparatus in which the Toshiba inverter is incorporated or to any equipment that is used in combination with the Toshiba inverter, Nor shall Toshiba, its subsidiaries, affiliates or agents be liable for any compensatory damages resulting from such utilization, including compensation for special, indirect, incidental, consequential, punitive or exemplary damages, or for loss of profit, income or data, even if the user has been advised or apprised of the likelihood of the occurrence of such loss or damages.

For further information, please contact your nearest Toshiba Representative or International Operations-Producer Goods. The information in this brochure is subject to change without notice.

## TOSHIBA INDUSTRIAL PRODUCTS SALES CORPORATION

### International Operations

9-11, Nihonbashi-Honcho 4-Chome, Chuo-ku, Tokyo, 103-0023, Japan

Tel: (81)3-5644-5509, Fax: (81)3-5644-5519

<http://www.tips.toshiba.com.au/>